

Pattern 2

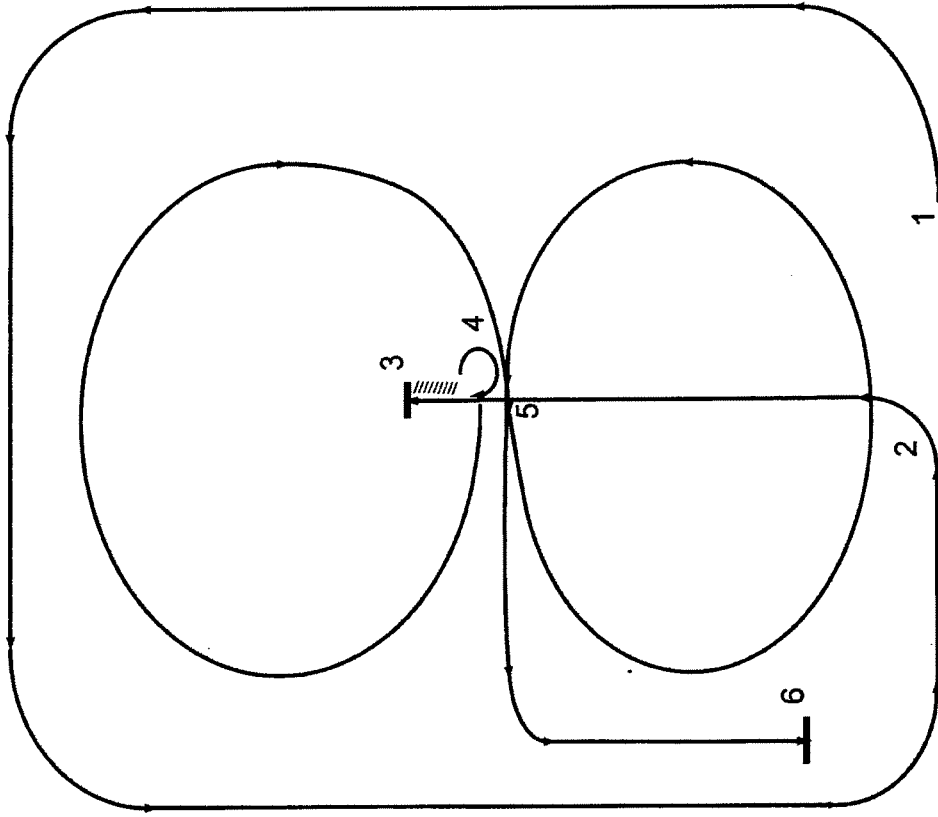

Horsemanship Pattern 2:

1. Circle the arena, on the left lead, at an extended lope.
2. Guide left and lope down the center of the arena with moderate speed.
3. Pass the center of the arena, stop and back to the center.
4. Execute a 3/4 turn to the right and lope a circle, to the right, with moderate speed.
5. Change leads and lope a circle, to the left, with moderate speed. After completing the circle, continue loping on the left lead toward the end of the arena.
6. Stop and pause to show completion of pattern.

Pattern 3

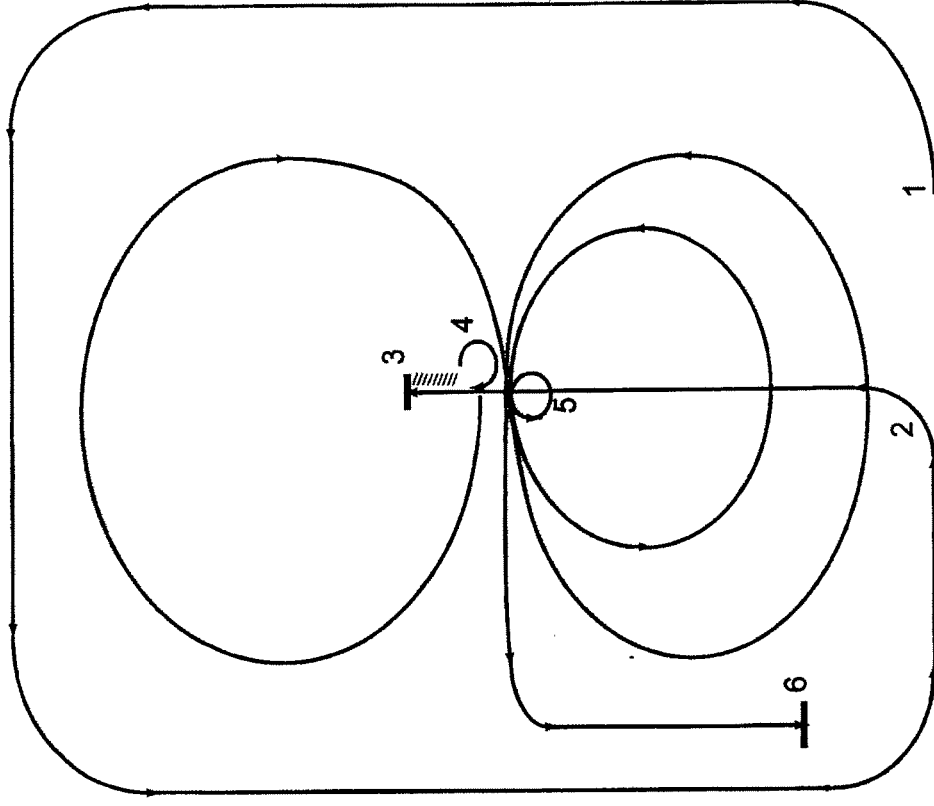

Horsemanship Pattern 3:

1. Circle the arena, on the left lead, at an extended lope.
2. Guide left and lope down the center of the arena with moderate speed.
3. Pass the center of the arena, stop and back to the center.
4. Execute a 3/4 turn to the right and lope a circle, to the right, with moderate speed.
5. Stop in the center, execute a 360 degree turn, to the left. Lope a small slow circle, to the left, followed by a larger, faster circle to the left. At the center of the arena, rate back to the slower speed and continue loping on the left lead toward the end of the arena.
6. Stop and pause to show completion of pattern.